

LOG SPLITTER

INSTRUCTION MANUAL

MODEL NO.:12232



Carefully read the instruction manual before you use this machine,
and save this instruction manual for future reference.

TABLE OF CONTENTS

1	WARNING SYMBOLS	3-4
2	GENERAL SAFETY INSTRUCTIONS	4-5
3	SPECIAL SAFETY INSTRUCTIONS FOR LOG SPLITTER	6-7
4	TECHNICAL SPECIFICATIONS	7-8
	Technical specifications	7
	Electrical safety	7-8
5	UNPACKING	9
6	LOOSE PARTS LIST	9
7	FEATURES	9-10
8	ASSEMBLY AND OPERATION	10-13
	Assembly	10-11
	Operation	11-12
	Freeing a jammed log	12
	Replacing hydraulic oil	13
	Sharpening wedge	13
9	TROUBLE SHOOTING	14
10	EXPLODED VIEW	15
11	PARTS LIST	16

WARNING SYMBOLS

WARNING! Standard graphic symbols are used on all machines in order to ensure complete safety of all parts of the log splitter. As these symbols are very important, read the information below attentively.



It is obligatory to read the machine's use and maintenance manual in full before using the machine.



It is obligatory to wear safety footwear at all times to provide protection against the risk of logs accidentally falling on feet.



It is obligatory to at all times to wear gloves which protect the hands against chips and splinters which may be produced during work.



It is obligatory at all times to wear goggles or a visor which protects the hands against chips and splinters which may be produced during work.



It is forbidden to remove or tamper with the protection devices and safety devices.



It is forbidden to stand in the range of action of the machine, apart from the operator, no other person or animal may be present within a radius of 5 meters from the machine.



Dumping of used oil in the environment is forbidden. The oil must be disposed of according to current legislation in the country where this operation is carried out.



Danger of cutting or crushing of the hand: never touch hazardous areas while the wedge is moving.



Warning: always pay attention to the movement of the log pusher.



Warning: never remove a log trapped in the wedge with your hands.



Warning: Before carrying out any maintenance operation described in this manual, disconnect the plug of the machine.



Warning: voltage as indicated on the rating plate.

GENERAL SAFETY INSTRUCTIONS

IMPORTANT! When using electrical tools, the following safety instructions should be observed to prevent the risk of electric shock, personal injury and fire. Read and observe these instructions carefully before using the tool.

1. Keep work area clean

Cluttered areas and benches invite injuries.

2. Consider work area environment

Do not expose power tools to rain. Do not use power tools in damp or wet locations. Keep work area well lit. Do not use power tools near flammable liquids or gases.

3. Guard against electric shock

Prevent body contact with grounded surfaces (e.g. pipes, radiators, ranges, refrigerators etc.)

4. Keep children away

Do not let visitors contact tool or extension cord. All visitors should be kept away from work area.

5. Store idle tools

When not in use, tools should be stored in a dry, high or locked-up place, out of the reach of children.

6. Do not force tool

It will do a better job and operate more safely at the rate for which it was intended.

7. Use right tool

Do not force small tools or attachments to do the job of a heavy duty tool. Do not use tools for other than their intended purpose; for example do not use a circular saw for cutting tree limbs or logs.

8. Dress properly

Do not wear loose clothing or jewelry. They can be caught in moving parts. Rubber gloves and non-skid footwear are recommended when working outdoors. Wear protection hair covering to contain long hair.

9. Use safety glasses

Also use a dust mask during pulverulent operations and wear ear protection. If the noise level exceeds 85 dB (A), ear protection is obligatory. Indicated noise levels may be exceeded dependent on the working environment and the material to be treated.

10. Use dust extraction

If dust extraction and collection devices are present on the tool, make sure that they will be used properly.

11. Do not abuse cord

Never carry tool by cord or yank it to disconnect it from wall outlet. Keep cord from heat, oil and sharp edges.

12. Secure work

Use clamps or a vise to hold the workpiece. It is safer and it frees both hands to operate tool.

13. Do not overreach

Keep proper footing and balance at all times.

14. Maintain tools with care

Keep tools sharp and clean for better and safer performance. Follow instructions for lubricating and changing accessories. Inspect tools cords periodically and, if damaged, have them repaired by an authorized service facility. Inspect extension cords periodically and replace if damaged. Keep handles dry, clean and free from oil and grease.

15. Disconnect tools

When not in use, before servicing, and when changing accessories such as blades, bits and cutters.

16. Remove adjusting keys and wrenches

Form the habit of checking to see that keys and adjusting wrenches are removed from the tool before switching it on.

17. Avoid unintentional starting

Do not carry plugged-in tools with finger on switch. Be sure that the tool is switched off before plugging in.

18. Outdoor use extension cords

When tools is used outdoors, use only extension cords intended for use outdoors and so marked.

19. Stay alert

Watch what you are doing. Use common sense. Do not operate tools when you are tired.

20. Check damaged parts

Before further use of the tool, a guard or other part that is damaged should be carefully checked to determine that it will operate properly and perform its intended function. Check for alignment of moving parts, binding of moving parts, breakage of parts, mounting, and any other conditions that may affect its operation. A guard or other part that is damaged should be properly repaired or replaced by an authorized service center unless otherwise indicated elsewhere in the instruction manual. Do not use tool if switch does not turn it on and off.

21. Warning

The use of any other accessory or attachment other than recommended in the instruction manual may present a risk of personal injury.

22. Have your tool replaced by an expert

This electric appliance is built in accordance with the relevant safety rules. Repair of electric appliances must only be carried out by experts otherwise it may cause considerable danger for user.

Store these instructions for future reference

SPECIAL SAFETY INSTRUCTIONS FOR LOG SPLITTER

1. The log splitter must always be used by one operator only.
2. Nobody must be allowed to use the log splitter unless they have read the instruction manual and have been instructed in the regulations to follow for correct and safe use.
3. The machine must be used by adults only. Use of the log splitter by apprentices of not less than 16 years of age must be supervised by an adult authorized to use the machine.
4. Never wear loose, unbuttoned clothing which may become trapped in moving parts.
5. Position the machine on a support surface of 60-75 cm height, free from any objects that could prevent complete freedom of movement for the operator while working. The surface must be perfectly leveled to prevent the machine from falling during operation.
6. It is prohibited to work with the machine on the ground. This is not only an uncomfortable working position but it can also be dangerous because the operator has to bring his face close to the machine, and thus risks being struck by chips or debris.
7. Check that the logs to be split are free from nails or wire, which may fly up or damage the machine, the ends of the logs must be cut square, branches must be cut off flush with the trunk.
8. Never try to split logs larger than those indicated in the technical specifications. This could be dangerous and may damage the machine.
9. Break wood in the direction of the grain, do not place wood across the log splitter and leave it in that position for splitting; it may be dangerous and may seriously damage the machine.
10. Never attempt to cut two logs at once, one may fly up and hit you.
11. If the log moves away from the blade, retract the ram or the blade and turn the log through 90°.
12. Do not attempt to load the log in the log splitter while the ram is in motion, you could get trapped and injured.
13. Keep your hands well away from any splits and cracks which open in the log; these may close suddenly and crush or amputate your fingers.
14. Never force the log splitter for more than 5 seconds keeping the cylinder under pressure in the attempt to split excessively hard wood. After this time interval, the oil under pressure is overheated and the machine could be damaged. It is thus better to stop and rotate the log by 90° to see whether it can be split in a different position. In any case, if you are not able to split the log, this means that its hardness exceeds the capacity of the machine and thus that log should be discarded so as not to damage the log splitter.
15. Do not force the blade by pushing the log on the upper part, as this can cause the blade to break or damage the body of the machine. Always set the log on the guides.
16. Never leave the machine unattended while it is running. If you leave the machine, even for a short time, remove the power supply or any possible cause of accidental start-up.
17. The log splitter must never be used by an operator who is under the influence of alcohol, drugs, medicines, or who is tired. A clear mind is essential for safety.
18. Never request the assistance of another

- person to help you remove a jammed log.
19. Do not use machines with electric motor if natural gas, petrol fumes or other inflammable vapours are present.
 20. Check that the electric circuit is adequately protected and that it corresponds with the power, voltage and frequency of the motor, check that there is a ground connection, and a regulation differential switch upstream.
 21. Never open the switch box on the motor. Should this be necessary, contact a qualified electrician.
 22. Make sure that the machine and the cable never come in contact with water.
 23. Treat the power cable with care, do not attempt to move the machine by pulling the cable, do not yank the cable to unplug it; keep the cable away from excessive heat, oil and sharp objects.
 24. Never leave the machine unattended with the power supply "on", also disconnect the power cable when not in use, when carrying out maintenance work, when changing attachment or moving the machine.

TECHNICAL SPECIFICATIONS

Technical specifications

Voltage	230V~
Frequency	50Hz
Power input	1500W
No load speed	2,950min ⁻¹
Insulation class	Class B
Protection degree	IP 54
Max. splitting force (tons)	5
Max. cylinder travel	390mm
Diameter of cylinder	55mm
Log Capacity	
Diameter	50-250mm
Length	520mm
Hydraulic oil capacity (Lt.)	2.8
Net weight	40kgs
Gross weight	42 kgs
L _{pa} (sound pressure level)	66.3 dB(A)
L _{wa} (sound power level)	79.3dB(A)

Electrical Safety

WARNING! Always check that the power supply corresponds to the voltage on the rating plate.

WARNING! Connect the main leads to a

standard 230V±10% (50Hz±1Hz) electrical supply which has protection devices of under-voltage, over-voltage, over-current as well as a residual current device (RCD) which maximum residual current rated at 30mA.

Replacing cables or plugs

Immediately throw away old cables or plugs when they have been replaced by new ones. It is dangerous to insert the plug of a loose cable in the wall outlet.

Using extension cables

1. As a supply for this machine always use an unloaded line and/or extension with conductor of at least 2.5mm² and protected with a 20A fuse. Be sure that this extension cable is not longer than 10 meters. Excessively long cables or inadequate section can cause voltage drops that prevent motor from developing its full power.
2. Only connect your machine and/or extension cable to an earthed electricity mains.
3. This machine can be switched to the single-phase network (230V/50Hz), if you are in doubt about the earth of the

electricity provisions, consult an electrician first.

Grounding

In the event of an electrical short circuit, grounding reduces the risk of electric shock by providing a path of least resistance to disperse electric current. This machine is equipped with a power cord having a equipment-grounding prong

1. Reduce the risk of electrocution by keeping all connections dry and off the ground. Do not touch plugs with wet hands. Failure to follow these warning could result in serious injuries.
2. This machine must have a ground prong in the plug to help ensure that it is grounded. Do not remove ground prong from plug to fit into a two-pronged outlet! If the plug will not fit the outlet, have the proper outlet installed by a qualified electrician.

UNPACKING

WARNING! To prevent accidental starting that could cause possible serious personal injury, assemble all parts to your log splitter before connecting it to power supply. Log splitter should never be connected to power supply when you are assembling parts, making adjustments, installing or removing drill bit, or when not in use.

- Carefully remove all parts from the carton and place the log splitter on a level work surface of the height not less than 60cm. Separate and check against the list of loose parts.

WARNING! If any parts are missing, do not operate this machine until the missing parts are replaced. Failure to do so could result in serious personal injury.

- Do not discard the packing materials until you have carefully inspected the log splitter, identified all parts, and satisfactorily operated your new log splitter.

Note: If any parts are damaged or missing, do not attempt to plug in the power cord and turn the switch on until the damaged or missing parts are obtained and are installed correctly.

LOOSE PARTS LIST

Check all loose parts from the box with the list below. Assemble according to the instruction on the following pages

1. Machine body assembly
2. Rolling wheels
3. Supporting leg
4. Safety guard for ZHB hydraulic control lever
5. Rubber knob for ZHB hydraulic control lever
6. 2 sets of screws, elastic washers and flat washers for assembling safety guard
7. 2 sets of Nuts and flat washers for assembling wheels
8. 2 sets of bolts, elastic washers and flat washers for assembling carrying handle
9. 2 sets of bolts, elastic washers and flat washers for assembling supporting leg
10. Carrying handle

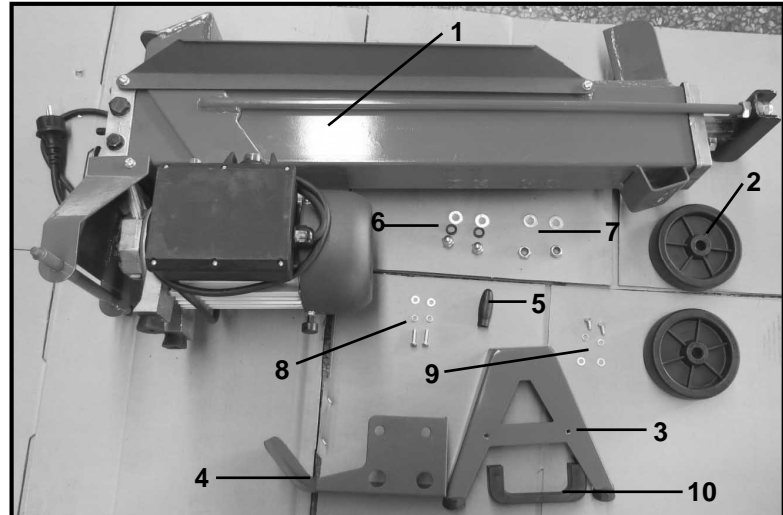

FEATURES

1. Before attempting to use, familiarize yourself with all the operating features and safety requirements of your log splitter.

1. Wedge
2. Oil tank
3. Carrying handle
4. Supporting leg
5. Motor w/push switch & circuit breaker
6. Rubber feet
7. Rolling wheel
8. ZHB hydraulic control lever
9. Safety guard for hydraulic control lever
10. Log pusher
11. Log retention brackets

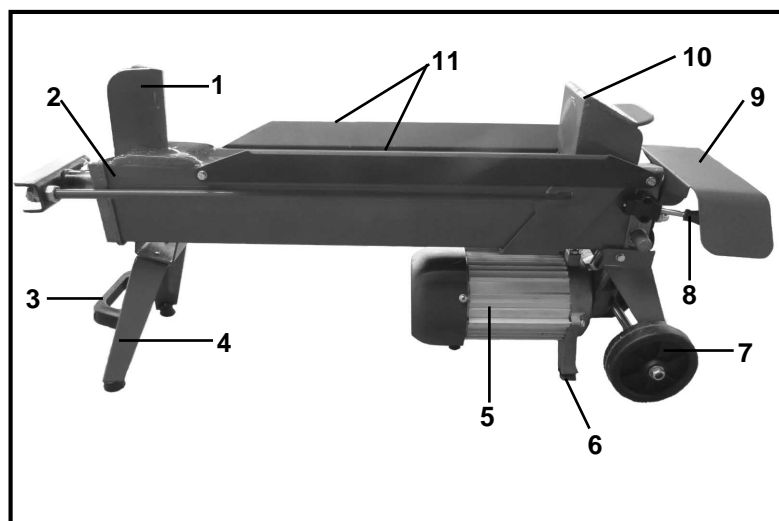

2. Size of the logs to be split
The figure 1 shows the maximum log sizes that can be split.

The diameter of the log is indicative: a small log can be difficult to split if it has knots or a particularly tough fiber. On the other hand, if

the wood has regular fibers it is not difficult to split logs with diameter greater than the maximum shown in fig. 1. **It is important not to insist when the log does not split on the first attempt, as the pump may be damaged by the overheating of the oil when the machine is made to work under the maximum stress in the attempt to split excessively hard wood.**

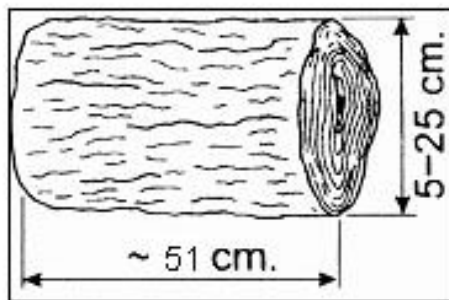

Fig. 1

3. Recommended oils

We recommend use of the following oils for the hydraulic cylinder.

SHELL TELLUS T22

ARAL VITAM GF22

SP ENERGOL HCP22

MOBILE DTE 11 OR equivalent

DO NOT USE OTHER GRADE OILS

4. Application conditions

This log splitter is a home use model. It is designed for operating under ambient temperature between $+5^{\circ}\text{C}$ and 40°C and for installation at altitudes no more than 1000mm above M.S.L. The surrounding humidity should less than 50% at 40°C . It can be stored or transported under ambient temperatures between -25°C and 55°C .

ASSEMBLY AND OPERATION

Warning! For your own safety, do not connect the log splitter to the power source until the machine is completely assembled and you read and understand the entire instruction manual.

Warning! For your own safety, never forget to bolt the support leg to the log splitter, lift the log splitter by the handles at both ends and place it on a 60-75cm high, stable, flat and level work surface.

Warning! Never use the log splitter if it is not in perfect order or if it needs servicing. Before starting work, check correct functioning of all the safety devices (ZHB, push button).

Assembly

1. Before operating the log splitter, it is necessary to fit the rolling wheel (2) Fig. 2, on supporting shaft (1) as shown. Insert the wheels on the shaft, block it using the washer (3), and fasten by the lock nut (4).
2. Assemble the supporting leg on the machine body, use the two bolts, elastic washers and flat washers to fasten the supporting leg on the machine body.

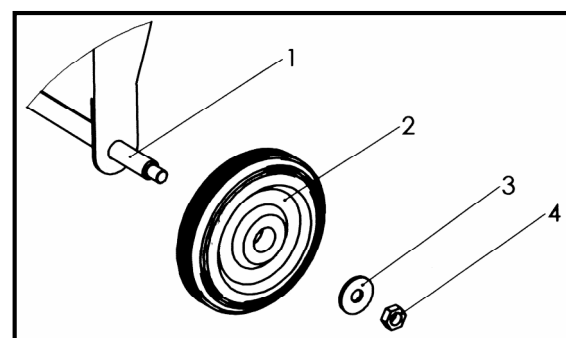

Fig. 2

3. Use two screws, elastic washers and flat washers to fasten the safety guard on the supporting bracket to protect the ZHB hydraulic control lever.
4. Turn the rubber knob onto the ZHB hydraulic control lever for comfortable operation.

Operation

Warning! Before operating the log splitter, the Bleed Screw (13) Fig. 3, should be loosened by some rotations until air can go in and out of the oil tank smoothly.

Air flow thru the Bleed Screw hole should be detectable while the log splitter is under operations.

Before moving the log splitter, make sure the Bleed Screw is tightened to avoid oil leaking from this point.

FAILED TO LOOSEN THE BLEED SCREW WILL KEEP THE SEALED AIR IN HYDRAULIC SYSTEM BEING COMPRESSED AFTER BEING DECOMPRESSED. SUCH CONTINUOUS AIR COMPRESSION AND DECOMPRESSION WILL BLOW OUT THE SEALS OF THE HYDRAULIC SYSTEM AND CAUSE PERMANENT DAMAGE TO THE LOG SPLITTER.

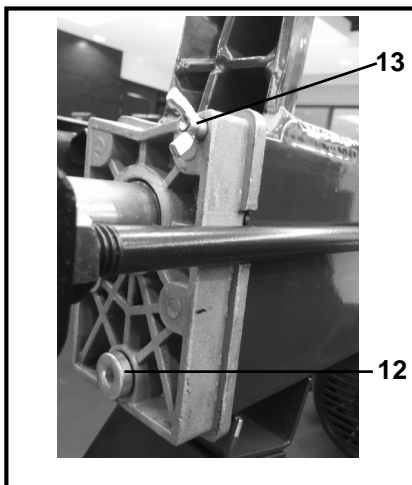

Fig. 3

DO NOT ADJUST THE MAX PRESSURE LIMITING SCREW (14) IN FIG. 4!

Max pressure was set before the log splitter ex work and the max pressure limiting screw is tightened to ensure the log splitter works under pressure no more than 4 tons. The setting was done by qualified mechanic with professional instruments.

Unauthorized resetting will cause the hydraulic pump fail to output enough splitting pressure or RESULT IN SERIOUS INJURY AS WELL AS DAMAGE TO THE MACHINE.

The max pressure limiting screw is protected by a plastic cap (15) as shown in Fig. 4, and never to loose and adjust it.

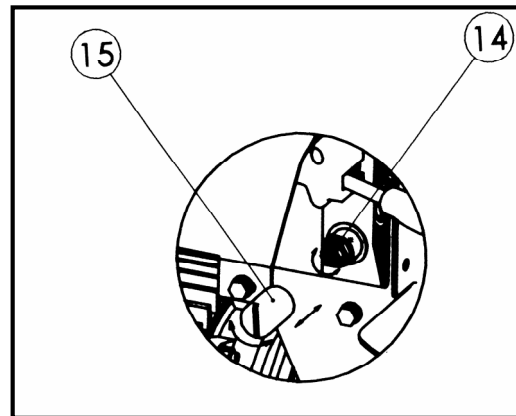

Fig. 4

This log splitter is equipped with “ZHB” control system that requires to be operated by both hands of the user – left hand controls the hydraulic control lever while right hand controls the pushbutton switch as shown in Fig. 5. The log splitter will freeze upon absence of either hand. Only after both hands release the controls, the log pusher starts to return backward to the starting position.

Never force the log splitter for more than 5 seconds by keeping pressure on it to split

excessively hard wood.



Fig. 5

After this time interval, the oil under pressure will be overheated and the machine could be damaged. For such extremely hard log, rotate it by 90° to see whether it can be split in a different direction. In any case, if you are not able to split the log, this means that its hardness exceeds the capacity of the machine and thus that log should be discarded to protect the log splitter.

NOTE: During operation, the metal part connected to the motor remains cold or in any case reaches a temperature only slightly higher than the ambient temperature. After several hours of use with particularly difficult wood, the pump may become very hot. This is not a dangerous situation for the machine, which returns to full functioning capacity after being cooled. On the other hand, it is very important not to cause overheating of the oil, and thus the pump, by forcing the machine in an attempt to split logs that exceed the capacity of the machine.

Always set logs firmly on the log retaining plates and work table. Make sure logs will not twist, rock or slip while being split. Do not force the blade by splitting the log on the upper part. This will break the blade or damage the machine.

Break log in the direction of its grown grain. Do

not place log across the log splitter for splitting. It may be dangerous and may seriously damage the machine.

Do not attempt to split 2 pieces of logs at the same time. One of them may fly up and hit you.

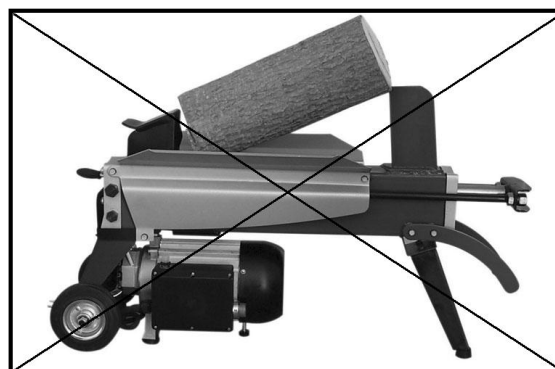

Fig. 6

Freeing a jammed log

1. Release both controls.
2. After the log pusher moves back and completely stops at its starting position, insert a wedge wood under the jammed log.
3. Start the log splitter to push the wedge wood to go completely under the jammed one.
4. Repeat above procedure with sharper slope wedge woods until the log is completely free.



Fig. 7

Do not try to knock the jammed log off. Knocking will damaged the machine or

may launch the log and cause accident.

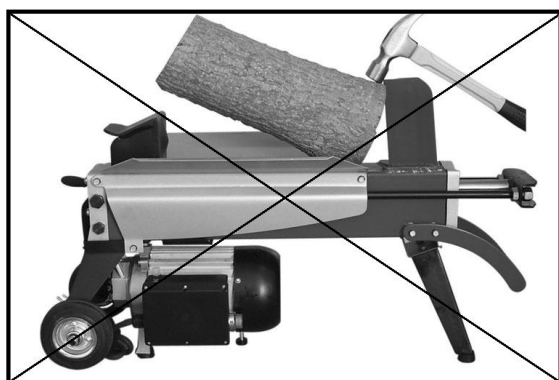

Fig. 8

Warning: Never mix oil with general waste! Used oil must be disposed of according to current regulations in the country where the machine is used.

Sharpening the wedge

After using the log splitter for some time, sharpen the wedge of the log splitter using a fine-toothed file and smooth any burrs or crushed area along the cutting edge.

Replacing hydraulic oil

Replace the hydraulic oil in the log splitter after every 150 hours of use. Take following steps to replace it.

1. Make sure all moving parts stops and the log splitter is unplugged.
2. Unscrew oil drain bolt with dipstick to remove it.
3. Turn the log splitter on the motor side over an 3 liters capacity container to drain the hydraulic oil off.
4. Turn the log splitter on the support leg side.
5. Refill fresh hydraulic oil at the volume as per the hydraulic oil capacity of a particular model indicated in the specifications table.
6. Clean the surface of Dipstick on the oil drain bolt and put it back into the oil tank while keep the log splitter vertically.
7. Make sure the level of the refilled oil is just between 2 grooves around the dipstick.
8. Clean the oil drain bolt before thread them back. Make sure they are tightened to avoid leakage before placing the log splitter horizontally.

Periodically check oil level to ensure it is between 2 grooves around the dipstick. Upon lower oil level, oil refilling is required.

TROUBLE SHOOTING

PROBLEM	PROBABLE CAUSE	REMEDY SUGGESTED
Motor stops starting	Overload protection device disengaged to protect the log splitter from being damaged	Let motor cool down, and push the button of the overload protection device to re-start the motor
Fails to split logs	Log is improperly positioned	Refer to "Log splitter operation" section for perfect log loading
	The sizes or hardness of the log exceeds the capacity of the machine	Reduce the log size before splitting it on the log splitter
	Wedge cutting edge is blunt	Refer to "Sharpening wedge" section to sharpen the cutting edge.
	Oil leaks	Locate leak(s) and contact the dealer
	Unauthorized adjustment was made on Max. Pressure Limiting Screw. Lower max pressure rating was set.	Contact the dealer
The log pusher moves jerkily, taking unfamiliar noise or vibrating a lot	Lack of hydraulic oil and excessive air in the hydraulic system	Check oil level for possible oil refilling. Contact the dealer.
Oil leaks around cylinder ram or from other points	Air sealed in hydraulic system while operating	Loosen bleed screw by some rotations before operating the log splitter
	Bleed screw is not tightened before moving the log splitter	Tight the bleed screw up before moving the log splitter
	Oil drain bolt with dipstick is not tight.	Tighten the oil drain bolt with dipstick
	Hydraulic control valve assembly and/or seal(s) worn.	Contact the dealer

EXPLODED VIEW

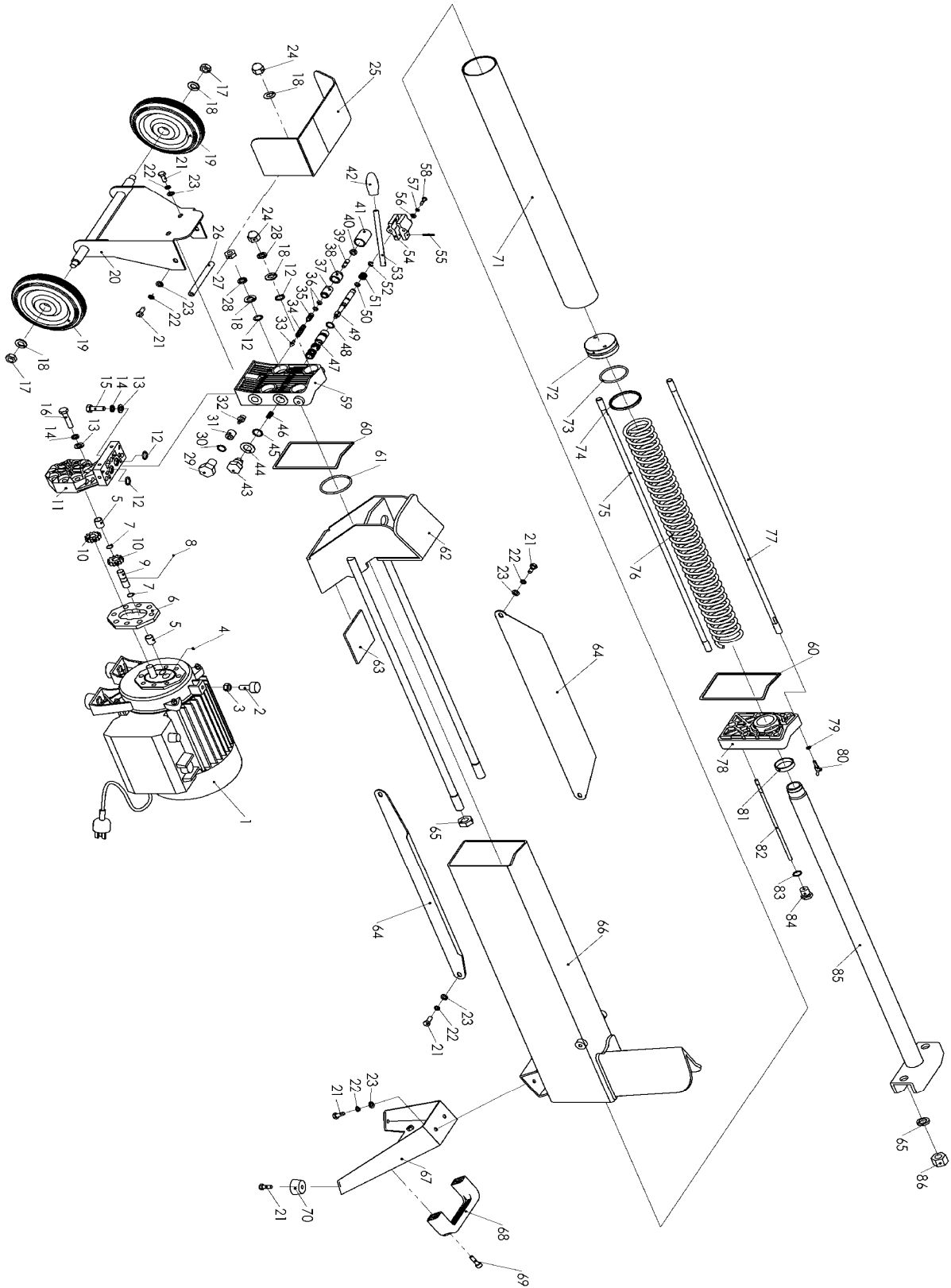

PARTS LIST

Part No.	Description	Q'ty	Part No.	Description	Q'ty
1	Motor	1	44	Copper washer 14	1
2	Rubber pad	1	45	O-ring 14x1.8G	1
3	Nut M8	1	46	Spring II	1
4	Pin ϕ 2.5x4	1	47	Controlling valve (GS)	1
5	Axle sleeve	3	48	O-ring 11.2x1.8G	5
6	Casting iron plate	1	49	Controlling shaft	1
7	Steel ring 10	2	50	Sealing ring 5.6x1.8G	1
8	Steel ball ϕ 2.5	1	51	Spring I	1
9	Gear shaft	1	52	E-ring	1
10	Gear	2	53	Handle	1
11	Gear pump cover	1	54	Fixing bracket	1
12	O-ring 9.5x2.65G	6	55	Elastic pin 3x20	1
13	Flat washer 8	9	56	Flat washer 5	2
14	Elastic washer 8	9	57	Elastic washer 5	2
15	Bolt M8x30	3	58	Screw M5x16	2
16	Bolt M8x55	6	59	Front cover	1
17	Locking nut M10	2	60	Sealing ring	2
18	Flat washer 10	6	61	O-ring 48.7x3.55G	1
19	Rolling wheel	2	62	Log pusher	1
20	Rolling wheel bracket	1	63	Plastic pad	2
21	Bolt M6x12	18	64	Log retention bracket	2
22	Elastic washer 6	18	65	Nut M14	4
23	Flat washer 6	18	66	Oil tank	1
24	Nut M10	2	67	Supporting leg	1
25	Safety cover	1	68	Carrying handle	1
26	Support shaft	1	69	Bolt M6x25	2
27	Nut M10	2	70	Rubber foot	4
28	Elastic washer 10	4	71	Cylinder tube	1
29	Hex-bolt M14x20	1	72	Piston	1
30	O-ring 11.8x1.8G	1	73	O-ring 43.7x3.55G	1
31	Screw	1	74	Plastic ring	1
32	Oil valve	1	75	2-head rod (A)	2
33	Cone valve	1	76	Spring	1
34	Adjusting spring	1	77	2-head rod (B)	2
35	Short shaft	1	78	Rear cover	1
36	O-ring 4.87x1.8G	2	79	O-ring 3.6x1.8G	1
37	Tube for short shaft	1	80	Screw M4x16	1
38	Nut	1	81	Dust proof ring FC3038x5	1
39	Screw M6x20	1	82	Oil level stick	1
40	Nut M6	1	83	O-ring 11.2x2.65G	1
41	Plastic cap	1	84	Oil level stick cap	1
42	Knob	1	85	Piston rod	1
43	Position bolt	1	86	Nut M10	2